

CLAMPRO®

X-PRO



44-PC AIR TOOL KIT

MODEL NO: CAT202

PART NO: 3120519

OPERATING & MAINTENANCE INSTRUCTIONS

UK
CA | CE

ORIGINAL INSTRUCTIONS

GC06/22 - Rev 2

INTRODUCTION

Thank you for purchasing this CLARKE Air Tool Kit.

Before attempting to use this product, please read this manual thoroughly and follow the instructions carefully. In doing so you will ensure the safety of yourself and that of others around you, and you can look forward to your purchase giving you long and satisfactory service.

Please keep these instructions in a safe place for future reference.

INVENTORY

When opening the case for the first time, check that all the items are present. Any damage or deficiency should be reported to your CLARKE dealer immediately.

Your CAT202 air tool kit should include the following:

AIR TOOLS

- 1 x ½" Reversible Ratchet Wrench
- 1 x Air Hammer
- 1 x ½" Square Drive Impact Wrench
- 1 x ¼" Die Grinder
- 1 x Blow Gun

GENERAL ACCESSORIES

<ul style="list-style-type: none">• 5 x Air Inlet Adaptors (¼"male)	<ul style="list-style-type: none">• 1 x Roll PTFE tape
<ul style="list-style-type: none">• 1 x Oil Bottle	<ul style="list-style-type: none">• Tyre pressure gauge
<ul style="list-style-type: none">• Tyre inflating nozzle	

FOR THE RATCHET WRENCH

<ul style="list-style-type: none">• 1 x 3/8 female to 1/2" male adaptor	
---	--

FOR THE AIR HAMMER:

<ul style="list-style-type: none">• 1 x Flat Chisel	<ul style="list-style-type: none">• 1 x Pointed chisel
---	--

FOR THE IMPACT WRENCH:

- | |
|--|
| <ul style="list-style-type: none">• 6 x Impact Sockets, 1/2" Square Drive Sizes: 9 mm, 11 mm, 14 mm, 17 mm, 22 mm, & 24 mm |
| <ul style="list-style-type: none">• 1/2" Extension bar |

FOR THE DIE GRINDER:

- | | |
|---|--|
| <ul style="list-style-type: none">• 5 x Assorted Stones, 6mm (1/4") shank | <ul style="list-style-type: none">• 2 x wrenches (11 and 17mm) |
| <ul style="list-style-type: none">• 5 x Assorted Stones, 3mm (1/8") shank | <ul style="list-style-type: none">• 1 x 1/8" (3mm) collet |

FOR THE BLOW GUN:

- | | |
|--|--|
| <ul style="list-style-type: none">• Air Inlet Adaptor (1/4"female) | <ul style="list-style-type: none">• 1 x Safety Nozzle |
| <ul style="list-style-type: none">• 2 x Nozzles (sports equipment) | <ul style="list-style-type: none">• 1 x Tapered Nozzle |
| <ul style="list-style-type: none">• 1 x Rubber nozzle | |

PRODUCT SPECIFICATIONS

IMPACT WRENCH

Min. Hose Size (ID)	3/8" (9.5mm)
Max Operating Pressure	90 psi (6.2 bar)
Air Consumption	6.5 cfm (average)
Drive size	1/2" Square
Max No Load Speed	8000 rpm @ 90psi
Max Torque	650 ft/lb (885 Nm)
Torque settings	1) - 185 ft/lbs 2) - 330 ft/lbs 3) - 650 ft/lbs 4) - In reverse - 670 ft/lbs
Air Inlet Size	1/4" BSP Female

Sound Pressure Level (LpA dB)	87 dB(A)
Sound Power Level (LwA dB)	98 dB(A)
Vibration Levels	4.35 m/s ² (uncertainty factor K= 1.5m/s ²)
Weight	2.49 kg
Wrench Dimensions (L x W x H)	197 x 190 x 68 mm

DIE GRINDER

Dimensions (L x W x H)	169 x 37 x 66 mm
Weight	0.39 kg
Collet size	1/4" and 1/8"
Air Inlet Size	1/4" BSP (female)
Operating Pressure	90 psi (6.2 bar)
Air Consumption	4 cfm (average)
No Load Speed	25000 rpm @ 90psi
Speed Settings and rpm	Setting 1 - 8,300 rpm Setting 2 - 16,000 rpm Setting 3 - 22,000 rpm Setting 4 - 25,000 rpm
Sound Pressure Level (LpA dB)	88 dB(A)
Sound Power Level (LwA dB)	98 dB(A)
Vibration Levels	2.9 m/s ²

AIR HAMMER/CHISEL

Maximum Operating Pressure	90 psi (6.2 bar)
Air Consumption (under load)	5 cfm
Max Blows per Min.	4500
Variable speed	Trigger operated
Air Inlet Size	1/4" BSP female thread
Vibration Levels	10.6 m/s ² (uncertainty factor K= 1.5m/s ²)
Sound pressure level	98 dB LpA
Sound power level	111 dB LWA
(uncertainty factor K	3 dB
Dimensions (L x W x H)	130 x 42 x 153 mm
Weight	1.05 kg
Chisel size	Overall length = 125 mm Body width = 11.6 mm Shank length = 42 mm Shank width = 10.2 mm

BLOW GUN

Min. Hose Size (ID)	3/8" (9.5mm)
Max Operating Pressure	90 psi (6.2 bar)
Dimensions (L x W x H)	133 x 19 x 176 mm
Weight	0.177 kg

RATCHET WRENCH

Min. Hose Size (ID)	3/8" (9.5mm)
Max Operating Pressure	90 psi (6.2 bar)
Air Consumption	4.5 cfm (max @90psi)
Drive size	1/2" Square
Max No Load Speed	180 rpm @ 90psi
Max Torque	60 ft/lb (85 Nm)
Air Inlet Size	1/4" BSP Female
Sound Pressure Level (LpA dB)	87 dB(A)
Sound Power Level (LwA dB)	98 dB(A)
Vibration Levels	4.35 m/s ² (uncertainty factor K= 1.5m/s ²)
Weight	1.18 kg
Wrench Dimensions (L x W x H)	265 x 47 x 53 mm

GENERAL SAFETY WARNINGS



CAUTION: FAILURE TO FOLLOW THESE PRECAUTIONS COULD RESULT IN PERSONAL INJURY AND/OR DAMAGE TO PROPERTY.

WORK ENVIRONMENT

1. ALWAYS keep the work area clean and tidy.
2. ALWAYS dress appropriately - Do not wear loose clothing or jewellery. Tie long hair out of the way.
3. ALWAYS keep children & visitors away - Do not let children handle the tools.
4. DO NOT operate the tool where there are flammable liquids or gases.

USE OF AIR POWERED TOOLS

1. ALWAYS stay alert and use common sense - do not operate air tools when you are tired or under the influence of alcohol, drugs or medication.

2. ALWAYS wear eye protectors when using the tool - Eye protection must provide protection from flying particles/objects from the front and the side. Ear protectors should also be worn.
3. DO NOT overreach - Keep proper footing and balance at all times.
4. DO NOT use any type of bottled gas as a source of power for this tool.
5. DO NOT connect the air supply hose with your finger on the trigger.
6. DO NOT exceed the maximum pressure for the air tools 90 psi / 6.2 bar.
7. ALWAYS check hoses for leaks and ensure that all connections are secure.
8. ALWAYS keep the air supply hose away from heat, oil and sharp edges.
9. DO NOT use the tools for any purpose than that described in this manual.
10. DO NOT fit the tools to any stand or clamping device that may damage it.
11. ALWAYS disconnect from the air supply when:
 - Performing maintenance
 - The tools are not in use.
 - The tools will be left unattended.
 - Moving to another work area.
12. DO NOT use any tool if it is defective or operating abnormally.
13. ALWAYS avoid damaging the tools by applying excessive force.
14. ALWAYS maintain the tools. Keep them clean for the safest performance.
15. Quick change couplings should not be located at the tool. They add weight and could fail due to vibration.
16. DO NOT force or misuse the tools which will do a better and safer job at the rate for which they are designed.
17. These tools vibrates with use. Vibration may be harmful to your hands or arms. Stop using the tool if discomfort, a tingling feeling or pain occurs. Seek medical advice before resuming use.

IMPACT WRENCH SPECIFIC HAZARDS

1. ALWAYS use the impact wrench as described in these instructions.
2. ALWAYS ensure the wrench is not moving and disconnected from the air supply when changing sockets etc. Use only impact wrench sockets....DO NOT use standard sockets.
3. ALWAYS finish tightening nuts with a torque wrench or suitable spanner to the correct torque as recommended by the vehicle manufacturer.
4. ALWAYS avoid excessive use of the impact wrench. When tightening a nut or bolt, only allow the wrench to impact briefly to avoid overtightening.

5. ALWAYS ensure that the socket is correctly installed before switching on.
6. ALWAYS wear suitable respiratory protection due to the possible presence of asbestos dust from vehicle brake linings.
7. ALWAYS disconnect from the air supply when changing sockets or when the wrench is not required for immediate use to avoid accidental starting
8. DO NOT carry the wrench by the air supply hose.
9. ALWAYS use both hands to control the wrench.
10. ALWAYS ensure the wrench has stopped before putting it down.

AIR HAMMER SPECIFIC HAZARDS

1. Only use accessories designed for use with this tool.
2. DO NOT use any of the chisels supplied as a hand struck tool.
3. DO NOT use blunt chisels which require excessive pressure and can break from fatigue. Always use sharp tools.
4. DO NOT mis-use the tool by prising which can result in a broken chisel.
5. ALWAYS ensure there are no hidden electrical cables, gas pipes etc, which could cause a hazard if damaged by action of the chisels.

BLOW GUN SPECIFIC HAZARDS

1. DO NOT use the blow gun if it is defective or operating abnormally.
2. ALWAYS maintain the blow gun with care. Keep it clean for the best and safest performance.
3. DO NOT discharge this blow gun at any persons or animals.
4. DO NOT insert into any part of yours or anyone elses body.
5. DO NOT point directly at a person's skin or at a fire.
6. DO NOT carry the blow gun by the air hose or with your finger on the trigger.

COMPRESSED AIR REQUIREMENTS



WARNING: COMPRESSED AIR CAN BE DANGEROUS. ENSURE THAT YOU ARE FAMILIAR WITH ALL PRECAUTIONS RELATING TO THE USE OF COMPRESSORS AND COMPRESSED AIR SUPPLY.

A typical air line layout is shown below. If an automatic in-line filter/regulator is used, it will keep the tool in good condition, but should be regularly checked & topped up with oil. CLARKE air-line oil should be used and the lubricator adjusted to approx 2 drops per minute.

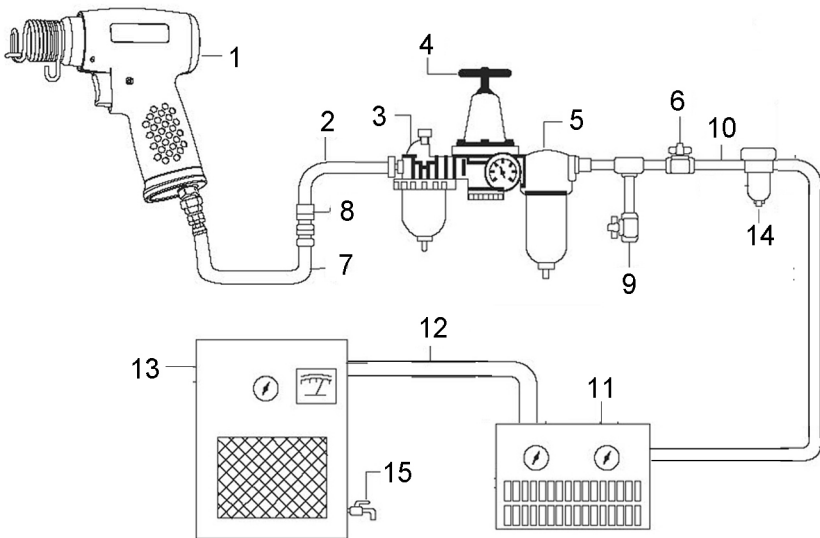

AIR SYSTEM LAYOUT :

- | | |
|-------------------------------|-------------------------------------|
| 1. Air Tool | 9. Drain Valve |
| 2. Air Hose | 10. 1/2" Or Larger Pipe And Fitting |
| 3. Oiler | 11. Air Dryer |
| 4. Pressure Regulator | 12. 1" Or Larger Pipe And Fitting |
| 5. Filter | 13. Air Compressor |
| 6. Shut Off Valve | 14. Auto Drain |
| 7. Whip Hose | 15. Drain Valve |
| 8. Coupler Body And Connector | |

Use only clean, dry, regulated compressed air as a power source.

Air compressors used with the tool must comply with the appropriate European Community Safety Directives.

A build-up of moisture or oil in the air compressor will accelerate wear and corrosion in the tool. ensure any moisture is drained from the compressor daily and the inlet filter is kept clean.

If an unusually long air hose is required, (over 8 metres), the line pressure or the hose inside diameter may need to be increased.

The air hose must be rated at least 150% of the maximum operating pressure of the air tool.

Never exceed the maximum operating pressure for the air tool. It is recommended that air pressure to this tools does not exceed 90 psi at the tool when running. Higher pressures and unclean air will shorten the life of an air tool due to faster wear and is a possible safety hazard.

BEFORE USE



WARNING: COMPRESSED AIR CAN BE DANGEROUS. ENSURE THAT YOU ARE FAMILIAR WITH ALL PRECAUTIONS RELATING TO THE USE OF AIR COMPRESSORS AND COMPRESSED AIR SUPPLY.

1. Remove the plastic blanking plug from the air inlet connection.
2. Pour 2-3 drops of CLARKE airline oil into the oil filling port. This should be done regardless of whether or not a lubricated air supply is to be used.
3. If required, connect an in-line mini oiler to the tool.
 - A mini oiler helps to prolong the life of any air tool.

4. Connect a suitable hose as shown or use the snap connector supplied to connect directly to the hose.

- PTFE tape may be useful for sealing threaded connections

5. Connect the other end of the hose to the compressor.
6. Turn on the air supply and check for air leaks. Rectify any found before proceeding.
7. If using a mini oiler, place a sheet of paper next the exhaust port and hold the throttle open for approximately 30 seconds. The oil volume is correctly set when a light stain of oil can be seen on the paper. Excessive oil should be avoided.
8. Your air tool is now ready for use.



THE IMPACT WRENCH



1	1/2" Square Drive	4	1/4" male inlet adaptor
2	Trigger	5	Air exhaust
3	Direction/Speed Control	6	Airline Inlet

FITTING THE IMPACT SOCKET



WARNING: NEVER USE STANDARD SOCKETS. THESE MAY SHATTER WITH SERIOUS CONSEQUENCES. ONLY USE IMPACT SOCKETS DESIGNED FOR USE WITH IMPACT TOOLS.

1. Select the impact socket you require, which must be in good condition and fit the tool exactly.
2. Push the socket onto the square drive shaft as shown.

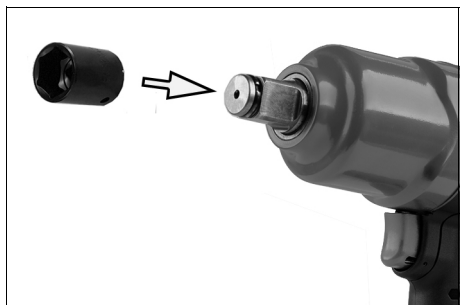

ADJUSTING THE DIRECTION AND SPEED

1. To adjust the speed, turn the switch slowly forward until the desired output is achieved.

- The three dots (small, medium and large) do not denote a specific power output but are only for reference.
- Setting 1 (small dot) is the least amount of power while setting 3 (large dot) is the most powerful.

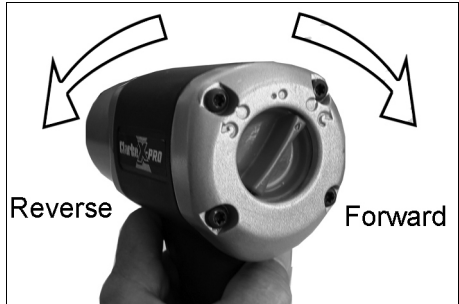

- The wrench operates at maximum power in reverse. This setting is for releasing threaded fasteners which may be tight.

NOTE: Where the torque setting is critical, the final tightening of nuts or bolts, must be by hand using a correctly calibrated torque wrench.



WARNING: WAIT UNTIL THE WRENCH HAS STOPPED ROTATING BEFORE OPERATING THE FORWARD/REVERSE SWITCH.

USING THE IMPACT WRENCH



WARNING: NEVER USE STANDARD SOCKETS. THESE MAY SHATTER WITH SERIOUS CONSEQUENCES. ONLY USE IMPACT SOCKETS DESIGNED FOR USE WITH IMPACT TOOLS.

LOOSENING A WHEEL NUT/BOLT

1. Remove any wheel trim, before selecting the appropriate socket and placing firmly on the square drive of the wrench.
2. With the FORWARD/NEUTRAL/REVERSE switch in the REVERSE running position, and holding the wrench firmly in BOTH HANDS, pull the trigger. The nut/bolt will be impacted repeatedly until it is loosened.

IMPORTANT: Release the trigger as soon as the nut begins to loosen.

3. Jack up the vehicle according to the vehicles handbook so that the wheel is clear of the ground, then proceed to fully undo the wheel nuts/bolts.

4. Soak rusted nuts/bolts in penetrating oil, and break rust seal before twisting off with the wrench.



WARNING: ENSURE THAT THE CORRECT SOCKET IS BEING USED FOR THE NUTS/BOLTS ON YOUR PARTICULAR VEHICLE. AN INCORRECT SOCKET SIZE IS LIKELY TO DAMAGE THE HEADS OF THE BOLTS/NUTS.

TIGHTENING A NUT/BOLT

1. Start the nut by hand, ensuring it is not cross threaded, then with the appropriate socket installed on the wrench, place it on the nut/bolt.
2. With the FORWARD/NEUTRAL/REVERSE selector in the clockwise (FORWARD) running position and holding the wrench firmly in BOTH HANDS, pull the trigger.
3. Run each nut/bolt up in turn until it is 'nipped' up only - do not tighten. When all nuts are nipped up, tighten progressively by pulling the trigger fully and allowing the action to operate briefly to prevent overtightening.
4. ALWAYS finish tightening with a torque wrench. The weight of the vehicle will need to be placed on the wheel to prevent it from rotating while the nuts are tightened. Ensure the final torque applied to the nuts/bolts meets the vehicle manufacturer's recommendations.

DISCONNECTING THE AIR SUPPLY

1. Do not disconnect the air hose until the supply is isolated at a shut-off valve.
2. Once the pressure has been isolated, disconnect the air supply hose from the impact wrench.
3. Shut down the compressor at the end of the work session.

THE HAMMER/CHISEL

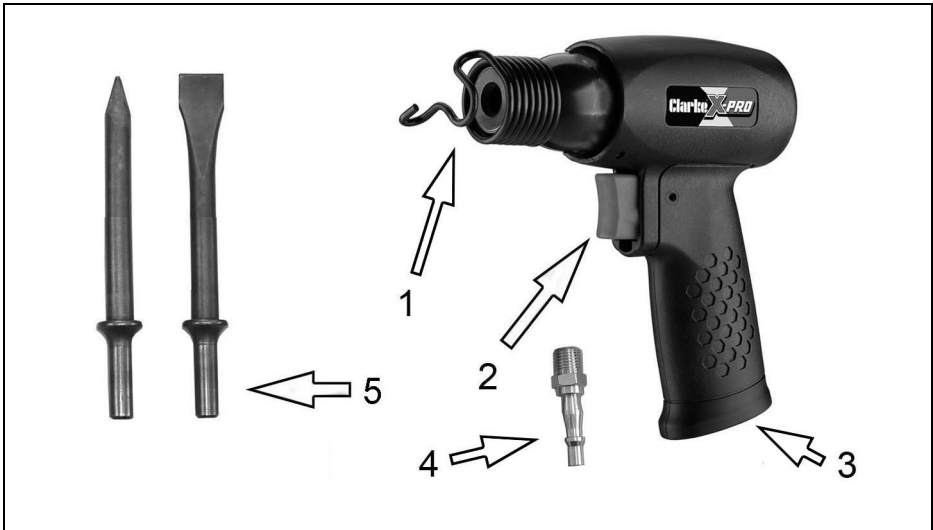

1	Retaining spring
2	Trigger
3	Air Inlet
4	Male inlet adaptor
5	Chisels (flat & pointed)

FITTING THE CHISEL

1. Select which chisel is best suited to the task.
2. First remove the retaining spring from the nose by unscrewing it.
 - Use the inboard lug to gain purchase.
3. Insert the chisel into the air hammer as shown.
4. Replace the retaining spring.
 - Use the lugs to help tighten.

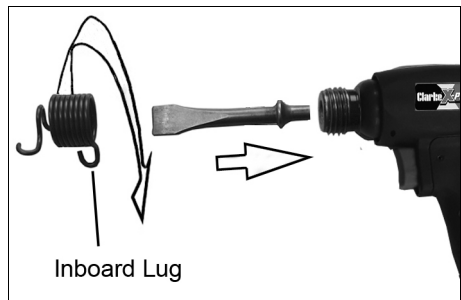

USING THE AIR HAMMER

1. Hold the tool firmly, then bring the tool towards the work at an angle of approximately 60-70 degrees.
2. Squeeze the trigger with the chisel in light contact with the work.
 - The chisel speed is controlled by squeezing the trigger.
3. Move slowly across the work surface. To remove scale, rust or other contaminants, only a light force should be required.
4. Release the trigger to stop operation, whilst maintaining contact with the work.
5. The tool may operate briefly after the trigger is released.

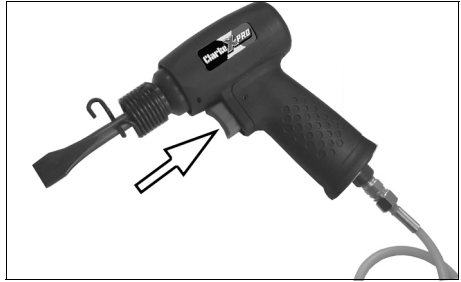

NOTE: The retaining spring has a life expectancy, depending upon the intensity of usage. It is recommended that you procure a spare spring for use in the event of failure occurring during the course of a particular job.

DISCONNECTING THE AIR SUPPLY

1. Do not disconnect the air hose until the supply is isolated at a shut-off valve.
2. Once the pressure has been isolated, disconnect the air supply hose.
3. Shut down the compressor at the end of the work session.

THE REVERSIBLE RATCHET WRENCH

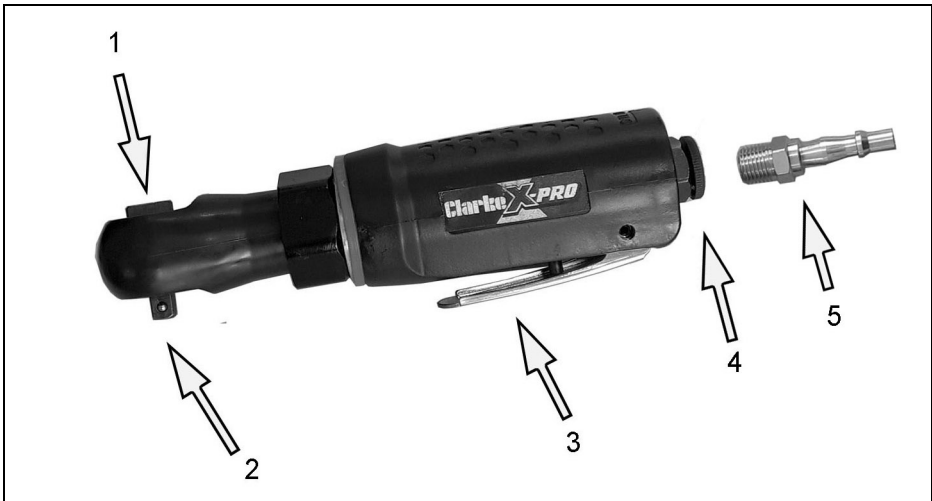

NO	DESCRIPTION	NO	DESCRIPTION
1	Forward/Reverse Switch	4	Air Inlet port
2	Square Drive Shaft	5	Male inlet adaptor
3	Trigger		

SETTING THE DIRECTION OF ROTATION



WARNING: ALWAYS WAIT UNTIL THE DRIVE SHAFT HAS STOPPED ROTATING BEFORE SETTING THE DIRECTION CONTROL.

To select the direction of rotation turn the direction control as follows.

- For tightening bolts/nuts, turn the direction control anti-clockwise to F (Forward).
- For loosening bolts/nuts, turn the direction control clockwise to R (Reverse).

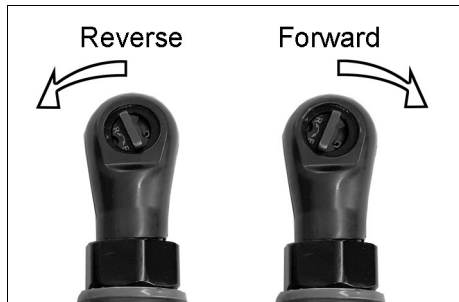

FITTING SOCKETS AND USING THE AIR RATCHET

1. Select the socket you require and push it onto the square drive shaft.
 - It clicks into place when secure.
2. Place the socket over the nut/bolt.
 - Take care that the socket is firmly engaged.
3. Squeeze the trigger against the body of the tool to start.
4. Release the trigger to stop the tool.
5. Always ensure the tool has stopped before putting it down.
6. When releasing very tight fastenings initially break loose by hand. Squeeze the trigger and the air tool will complete the job.
7. If necessary, use penetrating oil to assist in freeing off rusted fasteners.
8. When assembling, start turning fasteners by hand, then set the rotation forward or reverse. Apply the tool gently and squeeze the trigger to tighten with power.
9. Final tightening should be completed by hand.



THE BLOW GUN

The blow gun can be used with any of the nozzles listed on page 2.

A 13mm wrench will be required to remove the nozzle already fitted. A hose (not supplied) will be required to connect to the tyre inflating 2-way chuck nozzle.

The 0-50psi linear pressure gauge is for indication only and if accuracy is required, the pressure should be checked with a calibrated pressure gauge.

THE DIE GRINDER



NO	DESCRIPTION	NO	DESCRIPTION
1	17mm collet wrench	5	Air Exhaust Deflector
2	11mm collet wrench Air Inlet	6	Trigger
3	Grinding stones (3mm/6mm shank)	7	Male Connector
4	Speed Control	8	Collet retaining screw cap

INSTALLING THE COLLET

1. Select the grinding stone you require.
2. Two collets of different sizes are provided. Select whichever fits the shank of the stone you have chosen.
 - The larger collet is already installed in the grinder.

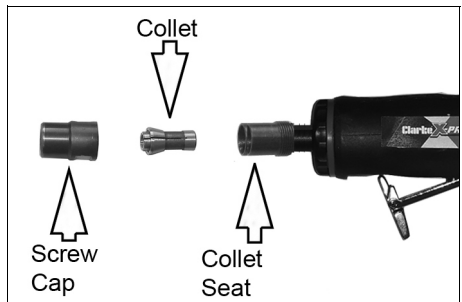

3. If another collet is to be used, undo the screw cap completely and pull out the collet from the collet seat. Replace it with the new collet and screw the cap loosely back on.

FITTING THE GRINDING STONE

IMPORTANT: Never use chipped or cracked grindstones.

1. Slip the shank of the chosen stone into the collet and tighten the screw cap finger tight.
2. Place the smaller of the two wrenches over the collet seat to stop the tool from rotating.
3. Use the larger wrench to fully tighten the collet and grip the stone in position as shown.

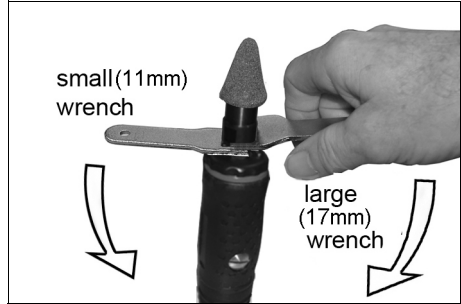

ADJUSTING THE SPEED

1. Set the tool speed by rotating the control to one of the four settings.
 - The numbers on the speed control knob indicate the speed setting when aligned with the reference mark on the air inlet +/-10%:

1	8,300 rpm
2	16,000 rpm
3	22,000 rpm
4	25,000 rpm

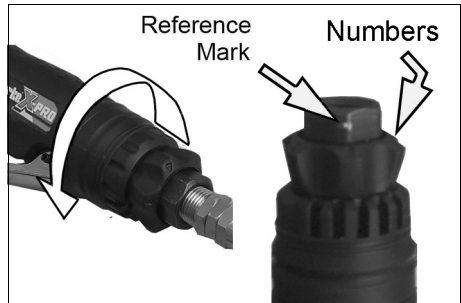

OPERATING THE DIE GRINDER

1. Slide the throttle locking lever forward while squeezing the trigger against the body of the tool.
2. Allow the tool to reach full working speed before presenting the grinding stone to the workpiece. Do not use excess pressure on the grinding stone as this will shorten its life.



3. Release the trigger to stop the grinder.
 - The tool will continue to rotate for a short time after the trigger has been released.
4. Always ensure the grinder has stopped before putting it down.

SETTING THE EXHAUST DEFLECTOR

The direction of the exhaust air leaving the tool can be adjusted by rotating the exhaust deflector.

Twist the exhaust deflector sleeve to direct the air as required away from the workpiece or operator.

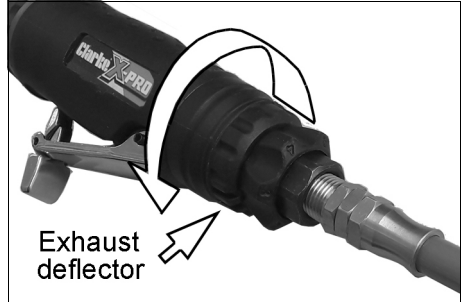

MAINTENANCE



WARNING: MAKE SURE THAT THE AIR TOOL IS DISCONNECTED FROM THE AIR SUPPLY BEFORE STARTING ANY CLEANING OR MAINTENANCE.

DAILY

1. Before use, drain water from the airline filter and compressor.
2. If no line lubricator or mini oiler is used, ensure that oil is applied to the tool on a daily basis through the air inlet connection. Run a few drops of CLARKE airline oil through the tool before use. It may be entered into the tool air inlet, (ensuring the strainer is clear), or into the hose at the nearest connection to the air supply.
3. This procedure should be repeated after every two to three hours of use, or at the start of the working day.
4. Check the air inlet screen filter for blockage and clean if necessary.
5. Keep the body of the tool clean and free from debris

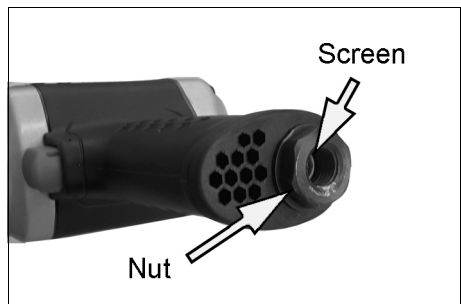

CLEANING & OVERHAUL

1. Grit or gum deposits in the tool may reduce efficiency.
2. After extensive use, remove the inlet screen filter and flush out the mechanism with gum solvent oil or an equal mixture of air-line oil and paraffin. Allow to dry before use.
3. If the tool still runs erratically or becomes inefficient, and the air supply is of good quality, it may be necessary to dismantle the air motor and replace worn or damaged parts. You may prefer to take the tool to your CLARKE dealer if internal maintenance is required.
4. The air tool may be dismantled by unfastening the bolts and removing the rear cover prior to replacing any worn or damaged parts.
5. While the impact wrench or air hammer is a dismantled state, it may be desirable to grease the hammer mechanism and applying a small amount of good quality bearing grease.

This may be better left to your CLARKE dealer.

STORAGE

If the tool is to be stored or is idle for longer than 24 hours, run a few drops of air-line oil into the air inlet and depress the trigger in order to lubricate the internal parts.

When not in use, the tool should be disconnected from the air supply and stored in a dry place out of the reach of children. Avoid storing in a damp environment.

Avoid storing air tools where the temperature is below 0°C.

PERFORMANCE

Please note that outside factors may affect the operation and efficiency of the air tool.

These include reduced compressor output, excessive drain on the airline, moisture ingress, restrictions in the air-line such as the use of connectors of incorrect size or poor condition which will reduce the air supply.

Your air tool has been designed to give long & trouble free service. If, however, having followed the instructions in this booklet carefully, you encounter problems, take the unit to your local CLARKE dealer.

TROUBLESHOOTING

SYMPTOM	PROBLEM	SOLUTION
Tool runs at normal speed but slows down under any load.	<ol style="list-style-type: none"> 1. Excessive pressure on tool. 2. Motor parts worn. 3. Worn or sticking mechanism due to lack of lubricant. 	<ol style="list-style-type: none"> 1. Reduce the force applied to the tool. 2. Return to CLARKE dealer for repair. 3. Drip air tool lubricating oil into air inlet. Allow oil to soak moving parts before using.
Tool runs slowly. Air flows weakly from exhaust.	<ol style="list-style-type: none"> 1. Motor parts jammed with gum/dirt. 2. Regulator in closed position. 3. General airflow blocked by dirt. 	<ol style="list-style-type: none"> 1. Examine inlet air filter for cleanliness. 2. Adjust regulator to open position. 3. Operate tool in short bursts.
Tool will not run. Air flows freely from exhaust.	<ol style="list-style-type: none"> 1. Motor vanes stuck due to buildup of foreign material. 	<ol style="list-style-type: none"> 1. Disconnect air supply and rotate tool assembly manually. 2. Try operating tool in short bursts. 3. Tap motor housing gently with a rubber mallet. 4. Drip a few drops of air tool lubricating oil into air inlet to soak moving parts.
Tool will not shut off.	<ol style="list-style-type: none"> 1. O-rings damaged or ill-fitting in seat. 	<ol style="list-style-type: none"> 1. Return to CLARKE dealer for repair.

ACCESSORIES

A wide range of accessories is available including filter/regulators, lubricators, high-pressure hoses (5 to 50 metres) etc.

Contact your CLARKE dealer for further information or CLARKE International Service Department on 01992 565333.

CLARKE Air Line Oil (part no. 3050825) is available from your CLARKE dealer.

COMPONENT PARTS - IMPACT WRENCH

No	Description
1	Main housing
2	O-ring
3	Trigger
4	Pin
5	E-ring
6	Bearing
7	Rear plate
8	Cylinder
9	Bolt
10	Rotor
11	Spring
12	Rotor blade
13	Front plate
14	Bearing
15	Hammer cage
16	Hammer dog
17	Hammer pin
18	Anvil
19	O-ring
20	Retainer bolt
21	Bushing

No	Description
22	Gasket
23	Front housing
24	Grease cap
25	Gasket
26	O-ring
27	Switch
28	Spring
29	Steel ball
30	O-ring
31	Rear cover
32	Set screw
33	Exhaust deflector
34	Cushion
35	Bolt
36	Circlip
37	Spacer
38	Oil seal
39	Tilt valve
40	Spring
41	O-ring
42	Air inlet

PARTS DIAGRAM - IMPACT WRENCH

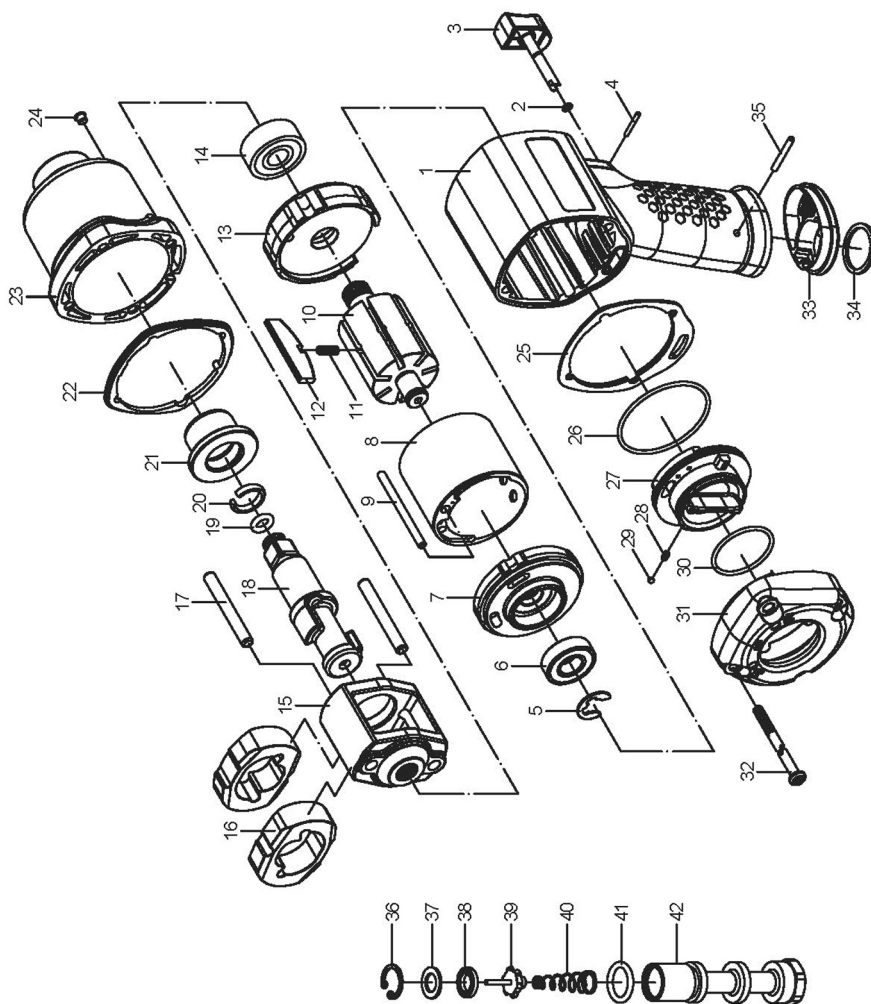

PARTS LIST & DIAGRAM -AIR CHISEL

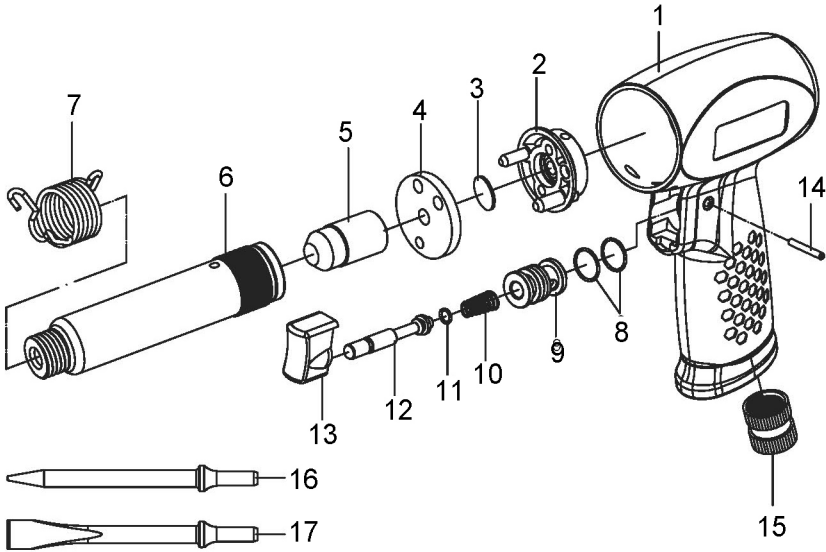

No	Description
1	Main housing
2	Valve seat
3	Valve plate
4	End cap
5	Piston
6	Cylinder
7	Retainer spring
8	O-ring
9	Valve sleeve
10	Spring

No	Description
11	O-ring
12	Valve stem
13	Trigger
14	Set pin
15	Air inlet
16	Pointed chisel
17	Flat chisel

COMPONENT PARTS DIAGRAM-RATCHET WRENCH

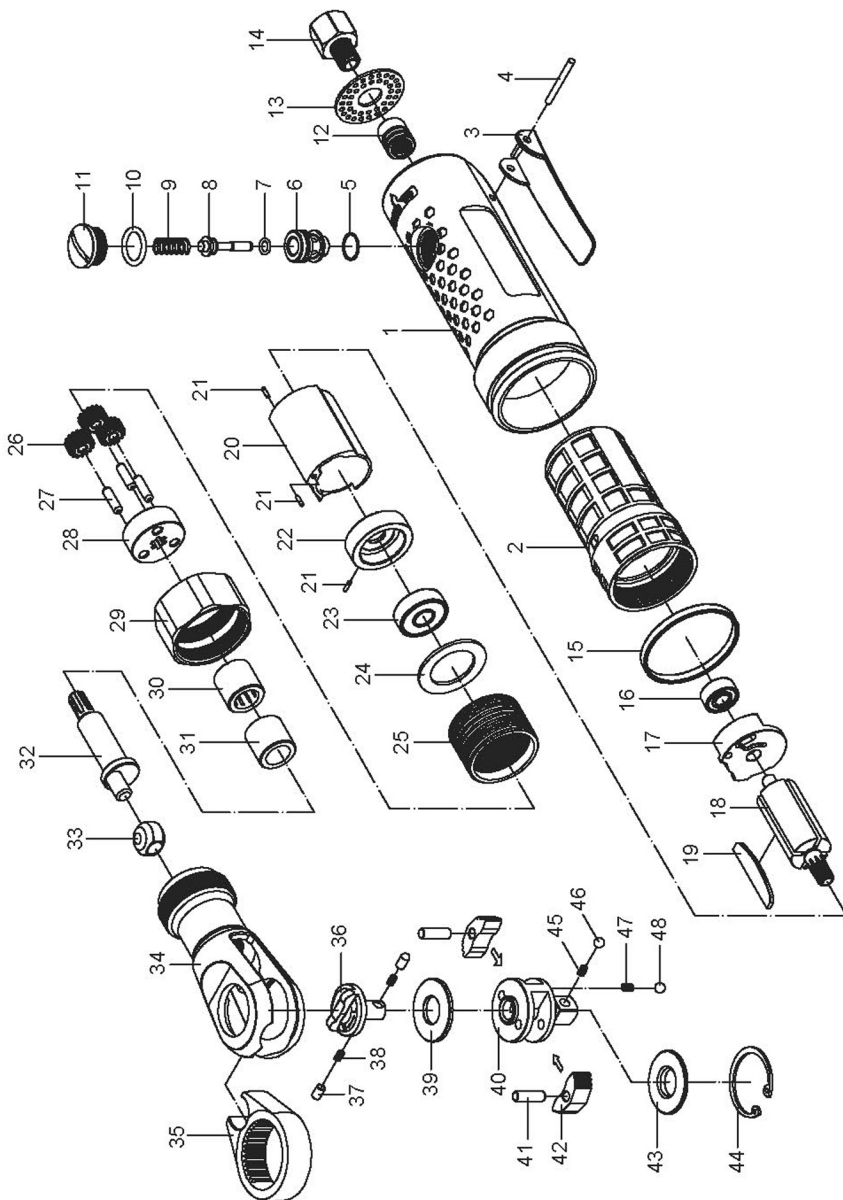

COMPONENT PARTS LIST - RATCHET WRENCH

No	Description
1	Main housing
2	Housing liner
3	Trigger
4	Roll pin
5	O-ring
6	Bushing
7	O-ring
8	Valve stem
9	Spring
10	O-ring
11	Screw cap
12	Nipple
13	Exhaust deflector
14	Air inlet
15	Decorative ring
16	Bearing
17	Rear plate
18	Rotor
19	Rotor blade
20	Cylinder
21	Set pin
22	Front plate
23	Bearing
24	Cushion

No	Description
25	Ring gear
26	Gear
27	Gear pin
28	Gear seat
29	Screw-on cap
30	Needle bearing
31	Bushing
32	Eccentric shaft
33	Drive bushing
34	Ratchet housing
35	Ratchet yoke
36	Forward/reverse knob
37	Sleeve
38	Spring
39	Washer
40	Ratchet head
41	Pin
42	Ratchet pawl
43	Washer
44	Circlip
45	Spring
46	Steel ball
47	Spring
48	Steel ball

PARTS LIST-DIE GRINDER

No	Description
1	Main Housing
2	Housing liner
3	Bushing
4	O-ring
5	Trigger
6	Lever
7	Spring
8	Roll pin
9	Trigger pin
10	Air inlet
11	Spring
12	Pin
13	O-ring
14	Air regulator
15	O-ring
16	Exhaust deflector
17	O-ring
18	O-ring
19	Valve stem
20	Spring

No	Description
21	O-ring
22	Screw
23	Bearing
24	Rear plate
25	Set pin
26	Rotor
27	Rotor blade
28	Cylinder
29	Bushing
30	Front plate
31	Steel ball
32	Bearing
33	Collet seat
34	Lock ring
35	Decoration ring
36	Front protective cover
37	Collet
38	Collet jacket
39	Small wrench
40	Large wrench

ACCESSORIES

A wide range of accessories is available including filter/regulators, lubricators, high-pressure hoses (5 to 50 metres) etc.

Contact your CLARKE dealer or the CLARKE International Service Department for further information.

A wide range of 1/2" square drive socket sets is available in the CLARKE catalogue.

CLARKE Air Line Oil (part no. 3050825) is available from your CLARKE dealer.

COMPONENT PARTS DIAGRAM - DIE GRINDER

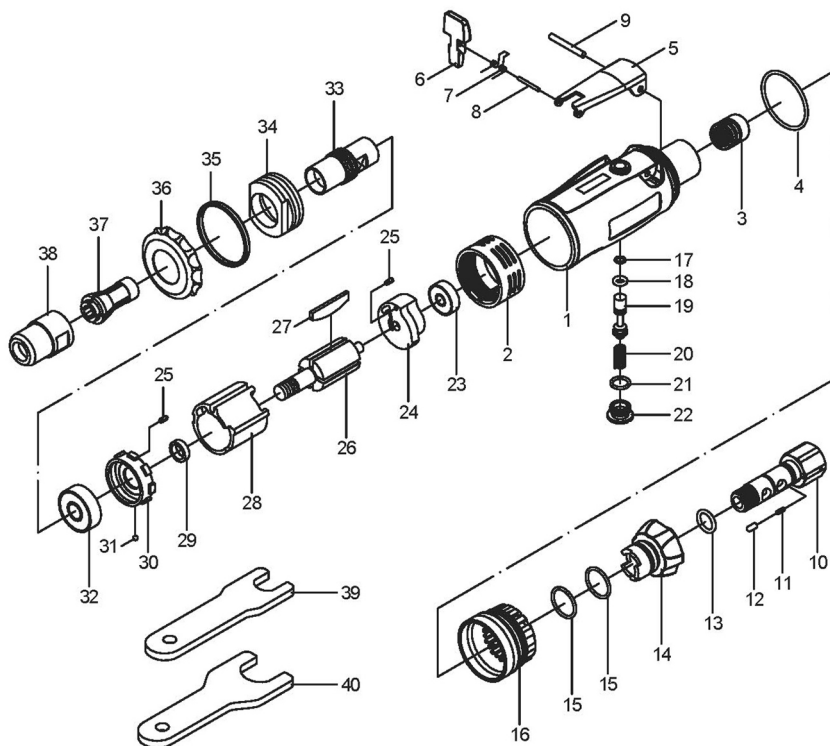

GUARANTEE

This product is guaranteed against faulty manufacture for a period of 12 months from the date of purchase. Please keep your receipt which will be required as proof of purchase.

This guarantee is invalid if the product is found to have been abused or tampered with in any way, or not used for the purpose for which it was intended.

Faulty goods should be returned to their place of purchase, no product can be returned to us without prior permission.

This guarantee does not effect your statutory rights.

DECLARATIONS OF CONFORMITY



Fitzwilliam Hall, Fitzwilliam Place, Dublin 2

DECLARATION OF CONFORMITY

This is an important document and should be retained.

We hereby declare that this product(s) complies with the following directive(s):
2006/42/EC Machinery Directive

The following standards have been applied to the product(s):

EN ISO 11148-4:2012, EN ISO 11148-6:2012, EN ISO 11148-9:2011

The technical documentation required to demonstrate that the product(s) meet(s) the requirement(s) of the aforementioned directive(s) has been compiled and is available for inspection by the relevant enforcement authorities.

The CE mark was first applied in: 2019

Product Description: 44pc Composite Air Tool Kit
Model number(s): CAT202
Serial / batch Number: N/A
Date of issue: 07/06/2022

Signed: 

J.A. Clarke
Director

CAT202 CE Clarke DOC 060722

Page 1 of 1



Hemnoll Street, Epping, Essex CM16 4LG

DECLARATION OF CONFORMITY

This is an important document and should be retained.

We hereby declare that this product(s) complies with the following statutory requirement(s):

Supply of Machinery (Safety) Regulations 2008

The following standards have been applied to the product(s):

EN ISO 11148-4:2012, EN ISO 11148-6:2012, EN ISO 11148-9:2011.

The technical documentation required to demonstrate that the product(s) meet(s) the requirement(s) of the aforementioned legislation has been compiled and is available for inspection by the relevant enforcement authorities.

The UKCA mark was first applied in: 2022

Product Description: 44pc Composite Air Tool Kit
Model number(s): CAT202
Serial / batch Number: N/A
Date of issue: 07/06/2022

Signed: 

J.A. Clarke
Director

CAT202 UKCA Clarke DOC 060722

Page 1 of 1

A SELECTION FROM THE VAST RANGE OF

Clarke®

QUALITY PRODUCTS



AIR COMPRESSORS

From DIY to industrial, Plus air tools, spray guns and accessories.

GENERATORS

Prime duty or emergency standby for business, home and leisure.

POWER WASHERS

Hot and cold, electric and engine driven - we have what you need

WELDERS

Mig, Arc, Tig and Spot. From DIY to auto/industrial.

METALWORKING

Drills, grinders and saws for DIY and professional use.

WOODWORKING

Saws, sanders, lathes, mortisers and dust extraction.

HYDRAULICS

Cranes, body repair kits, transmission jacks for all types of workshop use.

WATER PUMPS

Submersible, electric and engine driven for DIY, agriculture and industry.

POWER TOOLS

Angle grinders, cordless drill sets, saws and sanders.

STARTERS/CHARGERS

All sizes for car and commercial use.

PARTS & SERVICE:

0208 988 7400

Parts Enquiries

Parts@clarkeinternational.com

Servicing & Technical Enquiries

Service@clarkeinternational.com

SALES: UK 01992 565333 or Export 00 44 (0)1992 565335

Clarke INTERNATIONAL Hemnall Street, Epping, Essex CM16 4LG
www.clarkeinternational.com